

FLOJET®

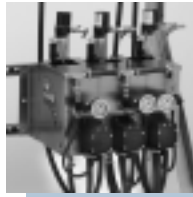

Car Wash Equipment Pumps and Accessories





ITT - FLOJET has been an expert in special application pumps for over 20 years, emerging as a leading global supplier for the car wash industry. Emphasizing quality and design, Flojet is ISO 9001 certified. Flojet is also proud to be the first ITT company in California to achieve certification under the ISO environmental standard 14001. With a worldwide customer service network and manufacturing facilities in both the United States and the United Kingdom, Flojet is committed to providing you with the finest products for your car wash equipment needs wherever you are.

TABLE OF CONTENTS	PAGE
Foam Arch System Pumps	
G57 Series, Automatic Demand Control	1
G57 Series, Dual and Quatro Pumps	2
Foam Applicator System Pumps	
5100 Series, Automatic Demand Control	3
Chemical Spray Pumps	
Duplex II Series, Automatic Demand 115V AC	4
Transfer/Dispensing Pumps	
4000 Series, Automatic Demand 115V AC	5
LF Series, Automatic Demand 115V AC	6
ET Series, Bypass 115V AC	6
Compressed Air Filter/Dryer	7
Accessories	8
Fittings	9

This catalog shows only the standard model pumps in Flojet's car wash line. Other models of are available. Flojet manufactures a complete line of small pumps to fit most applications. Contact us for special requests and additional information.

Discover Flojet at www.flojet.com

FOAM ARCH AND BRUSH SYSTEM PUMPS



G57 SERIES AIR OPERATED DIAPHRAGM PUMPS

Automatic Demand Control

FEATURES

- Chemical resistant Polypropylene housing with Viton® and Santoprene® elastomers
- Quiet operation with large exhaust muffler
- Easy installation with quick disconnect ports
- Duplex diaphragm design
- Patented shuttle valve, eliminates stalling
- Compact size

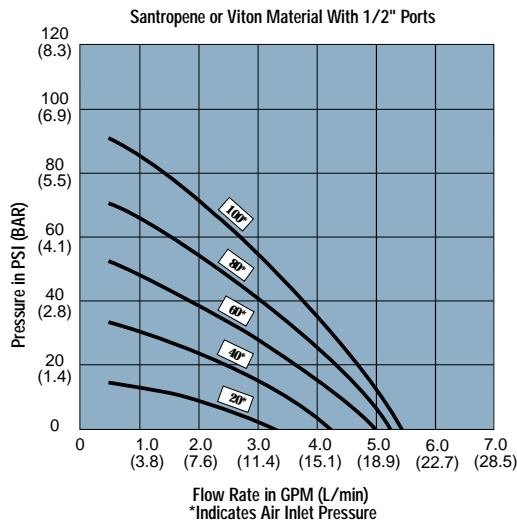

Standard Model Numbers, Santoprene® fitted	
Model No.	Fittings Description
G575205	3/8" barb port, 1/4" brass air inlet port
G575215	1/2" barb port, 1/4" brass air inlet port
G575225	3/4" barb port, 1/4" brass air inlet port
G575208	3/8" barb port, 1/4" plastic air inlet port
G575218	1/2" barb port, 1/4" plastic air inlet port
G575228	3/4" barb port, 1/4" plastic air inlet port
Standard Model Numbers, Viton® fitted	
Model No.	Fittings Description
G573205	3/8" barb port, 1/4" brass air inlet port
G573215	1/2" barb port, 1/4" brass air inlet port
G573225	3/4" barb port, 1/4" brass air inlet port
G573208	3/8" barb port, 1/4" plastic air inlet port
G573218	1/2" barb port, 1/4" plastic air inlet port
G573228	3/4" barb port, 1/4" plastic air inlet port

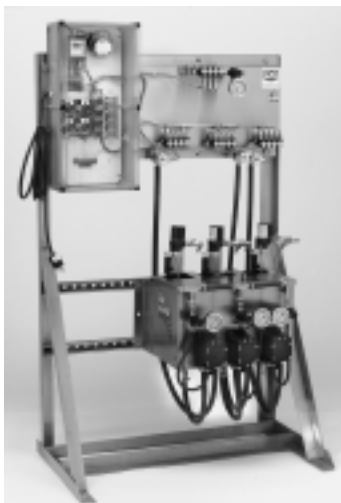

Specifications

Pump Design: Positive Displacement Double Diaphragm

Flow Rate: 5.0 GPM (11.9 L/min) Open Flow

Operating Pressure: 20 to 100 PSI (1.4 to 6.0 bar)

Liquid Inlet Pressure: 30 PSI (2.1 bar) Max.

Liquid Temperature: Min. 40° F (4.4° C)

Max. 140° F (60.0° C)

Priming: Dry 15ft. (4.5 m)

Wet 20ft. (6.1 m)

Air Supply Pressure: 20 to 100 PSI (1.4 to 6.9 bar)

Noise: Max 90 dB

FOAM ARCH, BRUSH AND BOOSTER PUMPS

G57 SERIES DUAL AND QUATRO HIGH FLOW DIAPHRAGM PUMPS

Air Operated Diaphragm Pumps

FEATURES

- Flows to 10 GPM (3.8 L/min) or 20 GPM (7.6 L/min)
- Chemical resistant Polypropylene housings with Viton® and Santoprene® elastomers
- Easy installation with 1/2" (12.7 mm) Dual and 3/4" (19.1 mm) Quatro pump manifolds
- Duplex diaphragm design
- Patented shuttle valves, eliminates stalling
- Compact size



Standard Model No.	Fittings Description
G257301A	Dual 10 GPM AOD Pump Viton® Elastomers, 1/2" NPTF Manifold Liquid, 1/4" Barb Air
G257302A	Dual 10 GPM AOD Pump Viton® Elastomers, 1/2" NPTF Manifold Liquid, 1/4" Quick Disconnect Elbow Air
G257501A	Dual 10 GPM AOD Pump Santoprene® Elastomers, 1/2" NPTF Manifold Liquid, 1/4" Barb Air
G257502A	Dual 10 GPM AOD Pump Santoprene® Elastomers, 1/2" NPTF Manifold Liquid, 1/4" Quick Disconnect Elbow Air
G457311A	Quatro 20 GPM AOD Pump Viton® Elastomers, 3/4" NPTF Manifold Liquid, 1/4" Barb Air
G457312A	Quatro 20 GPM AOD Pump Viton® Elastomers, 3/4" NPTF Manifold Liquid, 1/4" Quick Disconnect Elbow Air
G457511A	Quatro 20 GPM AOD Pump Santoprene® Elastomers, 3/4" NPTF Manifold Liquid, 1/4" Barb Air
G457512A	Quatro 20 GPM AOD Pump Santoprene® Elastomers, 3/4" NPTF Manifold Liquid, 1/4" Quick Disconnect Elbow Air

Specifications

Pump Design: Positive Displacement Double Diaphragm
Flow Rate (Dual): Up to 10.0 GPM (37.8 L/min)
Flow Rate (Quatro): Up to 20.0 GPM (75.6 L/min)
Operating Pressure: 20 to 100 PSI (1.4 to 6.0 bar)
Liquid Inlet Pressure: 30 PSI (2.1 bar) Max.
Liquid Temperature: Min. 40° F (4.4° C) Max. 140° F (60.0° C)
Priming: Dry 15ft. (4.5 m) Wet 20ft. (6.1 m)
Air Supply Pressure: 20 to 100 PSI (1.4 to 6.9 bar)
Noise: Max 90 dB

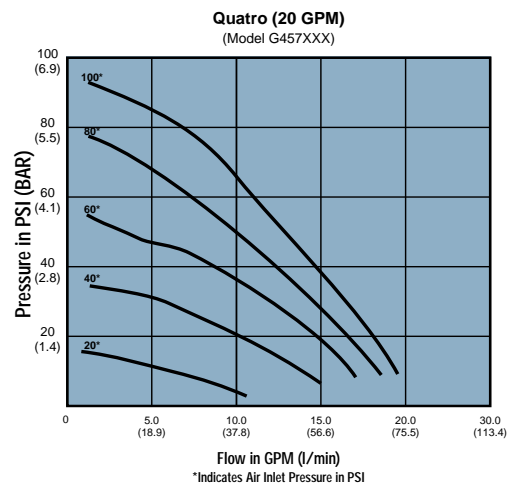
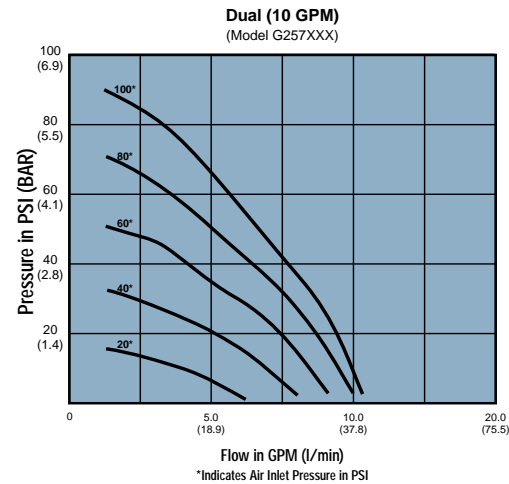

FOAM APPLICATOR SYSTEM PUMPS



5100 SERIES AIR OPERATED DIAPHRAGM PUMPS

Automatic Demand Control

FEATURES

- Oil resistant Acetyl copolymer housing with Santoprene®, Viton®, Geolast® and Buna elastomers
- Flow rates to 1.9 GPM (7.2 L/min)
- Operating pressures to 75 PSI (5.2 bar)
- Duplex diaphragm design
- Compact size

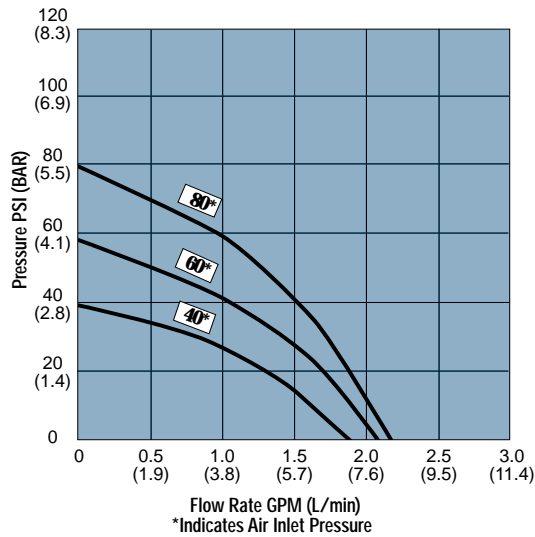

Standard Model No.	Description
5100-010	Buna Elastomers, 3/8" barb port fittings, 1/4" straight plastic air inlet port fittings
5100-020	Viton® Elastomers, 3/8" barb port fittings, 1/4" straight plastic air inlet port fittings
5100-040	Santoprene® Elastomers, 3/8" barb port fittings, 1/4" straight plastic air inlet port fittings
5100-050	Geolast® Elastomers, 3/8" barb port fittings, 1/4" straight plastic air inlet port fittings

Specifications

Pump Design: Positive Displacement Double Diaphragm

Flow Rate: 1.9 GPM (7.2 L/min) Open Flow

Operating Pressure: 20 to 75 PSI (1.4 to 5.2 bar) Max.

Liquid Inlet Pressure: 15 PSI (1.03 bar) Max.

Liquid Temperature: Min. 40° F (4.4° C)

Max. 140° F (60.0° C)

Priming: Dry 15 ft. (4.5 m)

Air Supply Pressure: 20 to 100 PSI (1.4 to 6.9 bar)

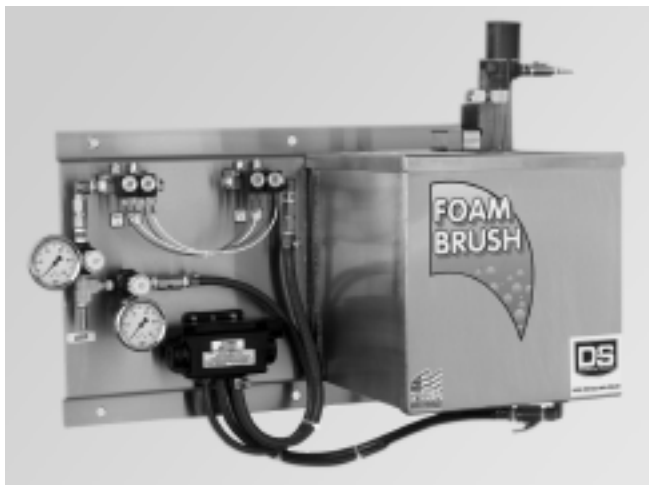

CHEMICAL SPRAY PUMPS

DUPLEX II SERIES DIAPHRAGM PUMPS

Automatic Demand 115 Volt AC

FEATURES

- Self priming up to 8 feet (2.4 m)
- Can run dry without damage
- Chemical resistant materials
- External bypass system standard
- Built-in back flow valve
- Heavy duty ball bearing drive system
- Optional sealed motor



Standard Model No.	Description
D1631H5011	Low Pressure Pump, EPDM CVA, Santoprene® Diaphragm 60 PSI (4.1 bar), Demand Switch, External Bypass
D1631F5011	Low Pressure Pump, Viton® CVA, Santoprene® Diaphragm 60 PSI (4.1 bar), Demand Switch, External Bypass
D1635E7011	High Pressure Pump, EPDM CVA, EPDM Diaphragm 100 PSI (6.9 bar), Demand Switch, External Bypass
D1635J7011	High Pressure Pump, Viton® CVA, EPDM Diaphragm 100 PSI (6.9 bar), Demand Switch, External Bypass

Specifications

Pump Design: Positive Displacement, Two-Chamber Diaphragm

Flow Rate: Low Pressure 1.6 GPM (6.0 L/min)

High Pressure 2.2 GPM (8.3 L/min)

Ports: 3/8" NPT Female

Motor: Permanent Magnet with Solid State Rectifier

Cycles: 50/60 Hz

Amps: Low Pressure 0.8 Amps (Max.)

High Pressure 1.0 Amps (Max.)

Liquid Temperature: Min. 40° F (4.4° C)

Max: 140° F (60.0° C)

UL, CUL Recognized

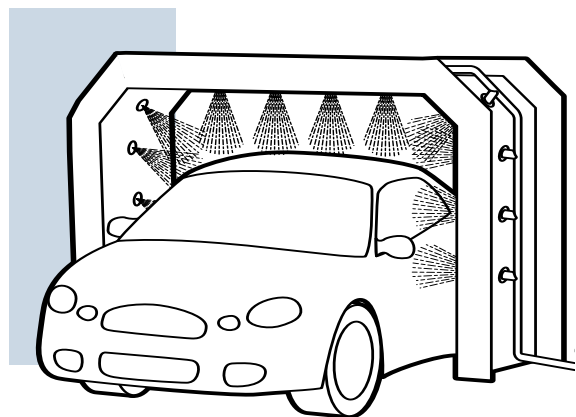
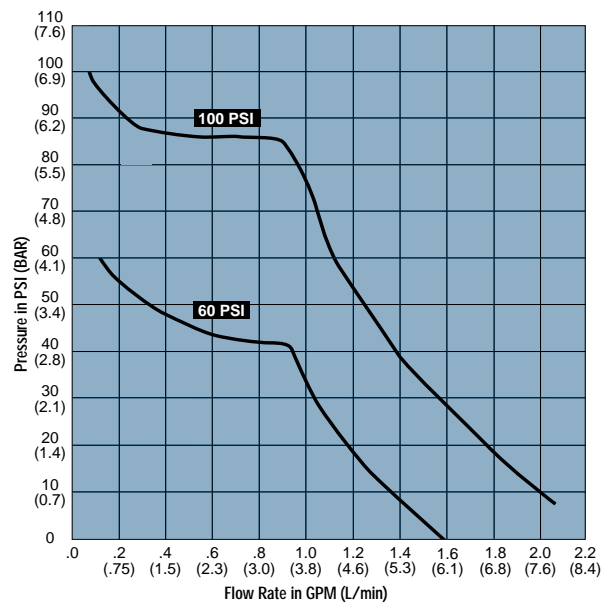

TRANSFER PUMPS

4000 SERIES DIAPHRAGM PUMPS

Automatic Demand 115 Volt AC



FEATURES

- Self priming up to 8 feet (2.4 m)
- Can run dry without damage
- Chemical resistant materials
- Built-in back flow valve
- Heavy duty ball bearing drive system
- Fan cooled motor standard

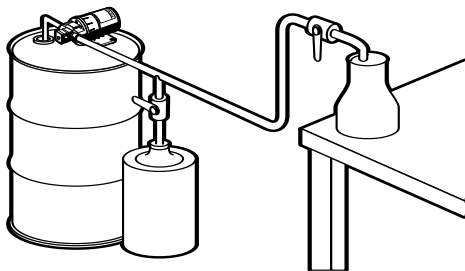
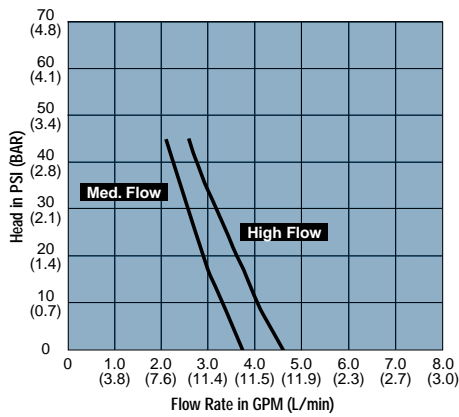

Standard Model No.	Description
4300-042	Medium Flow Pump, EPDM Valves, Santoprene® Diaphragm, 45 PSI (3.1 bar), Demand Switch
4300-501	Medium Flow Pump, Viton® Valves, Santoprene® Diaphragm, 45 PSI (3.1 bar), Demand Switch
4300-513	Medium Flow Pump, Viton® Valves, Santoprene® Diaphragm, 45 PSI (3.1 bar), Demand Switch, 6' Cord
4300-043	High Flow Pump, EPDM Valves, Santoprene® Diaphragm, 45 PSI (3.1 bar), Demand Switch
4300-515	High Flow Pump, Viton® Valves, Santoprene® Diaphragm, 45 PSI (3.1 bar), Demand Switch
4300-525	High Flow Pump, Viton® Valves, Santoprene® Diaphragm, 45 PSI (3.1 bar), Demand Switch, 6' Cord

Specifications

Pump Design: Positive Displacement, Two Chamber Design

Flow Rate: Low Flow Models 3.5 GPM (13.3 L/min) Open Flow
High Flow Models 5.0 GPM (18.9 L/min) Open Flow

Ports: 1/2" and 3/4" Hose Barb

Motor: Fan Cooled Permanent Magnet with Solid State Rectifier

Cycles: 50/60 Hz

Amps: Low Flow 0.9 Amps (Max.)

High Flow 1.2 Amps (Max.)

Liquid Temperature: Min. 40° F (4.4° C)

Max: 140° F (60.0° C)

DISPENSING PUMPS

LF SERIES DIAPHRAGM PUMPS

Automatic Demand 115 Volt AC

FEATURES

- Self priming up to 2.5 feet (0.76 m)
- Can run dry without damage
- Chemical resistant materials
- Compact design measuring 6.4" (164 mm) in length
- Sealed pressure switch and motor standard

Standard Model No.	Description
LF521401	Low Pressure Pump, Viton® CVA, Santoprene® Diaphragm, 40 PSI (2.8 bar), Demand Switch
LF521402	Low Pressure Pump, EPDM CVA, Santoprene® Diaphragm, 40 PSI (2.8 bar), Demand Switch

Specifications

Pump Design: Positive Displacement, Two Piston Design

Flow Rate: 0.8 GPM (xx L/min)

Ports: 3/8" Male Hose Barb

Motor: Rectified DC Motor

Cycles: 50/60 Hz

Amps: 0.30 Amps (Max.)

Liquid Temperature: Min. 40° F (4.4° C)

Max: 140° F (60.0° C)

CSA/CUS Recognized

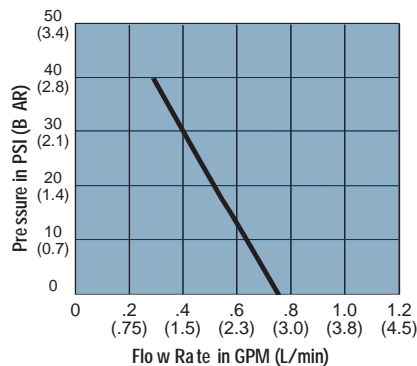

ET SERIES SOLENOID PUMPS

Automatic Bypass 115 Volt AC

FEATURES

- Self priming
- Includes internal diode
- UL and CSA recognized

Standard Model No.	Description
ET508221	EPDM Elastomer, 1/4" Hose Barb Ports
ET508223	EPDM Elastomer, 1/8" NPTF Ports
ET508224	Viton® Elastomer, 1/8" NPTF Ports

Specifications

Pump Design: Oscillating, Solenoid Coil with Diode

Flow Rate: 0.40 GPM (90.8 L/H), Open Flow

Ports: 1/4" Hose Barb or 1/8" NPT Female

Cycles: 50/60 Hz

Power Consumption: Nominal 46 Watts

UL Recognized

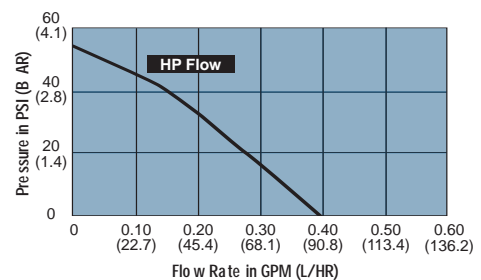

FILTER/DRYER

COMPRESSED AIR FILTER/DRYER

Extractor/Dryer® Series FJ520B

FEATURES

- Easy to install and maintain without removal
- Lightweight aluminum housing
- Immediate cost savings from decreased downtime
- Standard inlet and outlet NPT sizes
- Improved equipment performance and life
- Standard five micron rating
- Standard weep drain

Standard Model No.	Description
FJ520B	Extractor/Dryer
FJ0155K	Service Kit

Specifications

Material: Aluminum Housing

Port Size: 1/4" NPT Female

SCFM: 15 CFM

Maximum Pressure: 250 psi (17.2 bar)

DP: 6 psi (0.4 bar)

Size: 7 1/8" x 3" x 1 1/4"

Weight: 2.0 lb (0.91 kg)

The patented Extractor/Dryer® is a two-stage filter with a lightweight anodized aluminum housing. Designed primarily for the final usage of air, it will remove water, oil, and other contaminants from compressed air lines.



ACCESSORIES



Strainers

- Keep debris and particles from entering your FLOJET pump.
- Low profile design, for space saving installation.
- Threaded bowl makes cleaning quick and easy.

Part Number	Inlet	Outlet	Screen
01720-000	3/4" Barb	3/4" Barb	20 Mesh SS
01720-002	1/2" Barb	1/2" Barb	20 Mesh SS
01720-023	3/8" Barb 90°	3/8" Barb 90°	20 Mesh SS
01720-102	1/2" Barb	1/2" Barb	20 Mesh PP
01720-103	3/8" Barb	3/8" Barb	20 Mesh SS
01720-112	1/2" Barb	Quad Port 90°	20 Mesh PP
01720-123	3/8" Barb	3/8" NPT 90°	20 Mesh PP
01720-375	3/8" NPT(f)	3/8" NPT(f)	20 Mesh SS
01740-000	3/4" Barb	3/4" Barb	40 Mesh SS
01740-002	1/2" Barb	1/2" Barb	40 Mesh SS
01740-003	3/8" Barb	3/8" Barb	40 Mesh SS
01740-010	3/4" Barb	Quad Port 90°	40 Mesh SS
01740-012	1/2" Barb	Quad Port 90°	40 Mesh SS
01740-375	3/8" NPT(f)	3/8" NPT(f)	40 Mesh SS

SS=Stainless Steel PP=Polypropylene

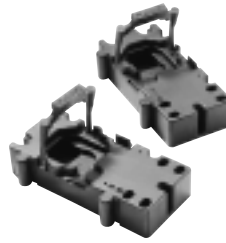

Universal Mounting Bracket

- Single brackets snap together easily for multiple pump installations.
- No additional hardware needed to mount pumps on bracket.

Applications

- For use with G Series, 5100 Series and Shurflo® air driven pumps.
- Ideal for mounting on rack or wall.

Part Number	Description
20982-100A	Single Pump Mounting Bracket

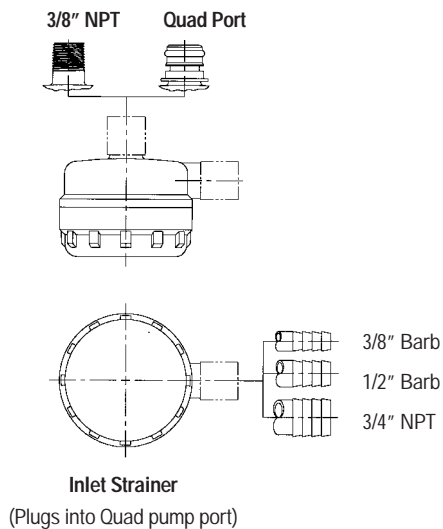
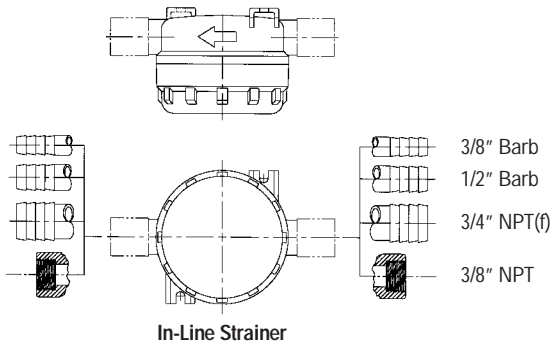

FITTINGS

AIR PUMP - LIQUID FITTINGS

Plastic (Celcon) Inlets & Outlets - Liquid

- For use with all 5100 Series Pumps.

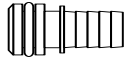

Part Number	Description
20325-031	3/8" Hose Barb, Straight
Packaged 1 per bag.	

Plastic (Polypropylene) Inlets & Outlets

- For use with all G57 Series Pumps.

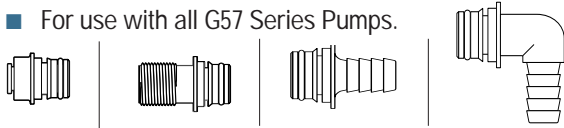

Part Number	Description	O-ring Mtl.
20381-026	10-13 mm (3/8" -1/2") Hose Barb, Straight	EPDM
20381-002	1/2" Hose Barb, Straight	EPDM
20381-006	3/4" Hose Barb, Straight	EPDM
20381-024	10-13 mm (3/8" -1/2") Hose Barb, 90° Elbow	EPDM
20381-009	1/2" Hose Barb, 90° Elbow	EPDM
20381-010	3/4" Hose Barb, 90° Elbow	EPDM
20381-070	10-13 mm (3/8" -1/2") Hose Barb, Straight	Viton®
20381-015	1/2" Hose Barb, Straight	Viton®
20381-014	3/4" Hose Barb, Straight	Viton®
20381-017	1/2" Hose Barb, Elbow	Viton®
20381-018	3/4" Hose Barb, Elbow	Viton®
20381-058	3/8" O.D. Tube, Straight, Push In Fitting	EPDM
20381-060	3/8" O.D. Tube, Straight, Push In Fitting	Viton®
20381-061	1/2" O.D. Tube, Straight, Push In Fitting	EPDM
20381-063	1/2" O.D. Tube, Straight, Push In Fitting	Viton®
20381-042	3/8" NPT Straight	EPDM
20381-043	3/8" NPT Straight	Viton®
20381-050	3/8" NPT Elbow	EPDM
20381-052	3/8" NPT Elbow	Viton®
20381-039	1/2" NPT Straight	EPDM
20381-040	1/2" NPT Straight	Viton®
20381-047	1/2" NPT Elbow	EPDM
20381-049	1/2" NPT Elbow	Viton®

Packaged 2 per bag.

AIR PUMP - AIR FITTINGS

Brass CO2/Air Inlets with Shutoff Valve

- For use with all 5100 Series and G57 Series Pumps.
- Automatically shuts off CO2 supply to pump, when unplugged.

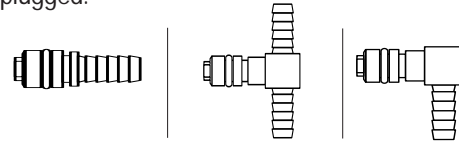

Part Number	Description
01510-000	1/4" Hose Barb, Straight
01520-000	1/4" Hose Barb, Tee
01521-000	1/4" Hose Barb, Elbow

Plastic (Celcon) CO2/Air Inlets

- For use with all 5100 Series and G57 Series Pumps.



Part Number	Description
20325-033	1/4" Hose Barb, Straight
Packaged 1 per bag.	

ELECTRIC PUMP FITTINGS

Nylon Barbed Elbow

- For use with all Duplex II Series (3/8" NPT only).

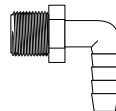

Part Number	Description
91010-001	3/8" NPT Male x 3/8" Barb
91010-005	3/8" NPT Male x 1/2" Barb
91010-033	3/8" NPT Male x 1/4" Barb

Nylon Barbed Straight

- For use with all Duplex II Series (3/8" NPT only).

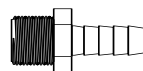

Part Number	Description
91010-002	3/8" NPT Male x 3/8" Barb
91010-006	3/8" NPT Male x 1/2" Barb
91010-032	3/8" NPT Male x 1/4" Barb



ITT - Flojet has maintained a strong
development and new product
introduction pace to meet the challenge
of satisfying our customers' evolving
market needs ... products that can be
purchased with the same high degree
of confidence that buyers have placed
in our products for over 30 years.

Distributed By:



Engineered for life

www.flojet.com

USA

Flojet
20 Icon
Foothill Ranch
CA 92610

Tel: +1 949 859 4945
Fax: +1 949 859 1153

UK

Flojet
Bingley Road, Hoddesdon
Hertfordshire EN11 OBU

Tel: +44 (0) 1992 450145
Fax: +44 (0) 19920467132

Germany

Jabco GmbH
Oststraße 28
22844 Norderstedt

Tel: +49 40 53 53 73 0
Fax: +49 40 53 53 73 11

Japan

NHK Jabco Co Ltd
3-21-10, Shin-Yokohama
Kohoku-ku
Yokohama 222-0033

Tel: 0 45 475 8906
Fax: 0 45 477 1162

Italy

Jabco Marine Italia
Via Tommaseo, 6
20059 Vimercate, Milano

Tel: +39 039 685 2323
Fax: +39 039 666 307